



LEADING SUPPLIER IN PAPER & CORRUGATING INDUSTRY

# INTRODUCTION

---

Kaybee Machinery Co (KBMC) has been a pioneering force in the Paper and Packaging Industry of Pakistan since its inception in 2003. Founded with a vision to revolutionize the industry by providing cutting-edge technology & innovative solutions, KBMC has established itself as a trusted partner for those seeking to enhance their productivity & efficiency.

With a focus on delivering high-quality machinery and exceptional customer service, KBMC has played a significant role in shaping the paper and packaging landscape in Pakistan. Over the years, the company has expanded its product portfolio to cater to diverse needs, offering a wide range of equipment and services tailored to meet the evolving demands of the industry.

KBMC's expertise spans across various aspects of paper and packaging production, including papermaking, converting, & packaging machinery. Their product range includes state-of-the-art machines for tissue production, paperboard manufacturing, and packaging solutions.

The company's commitment to innovation is evident in its approach to problem-solving and customer satisfaction. By staying abreast of the latest technological advancements and industry trends, KBMC has consistently delivered customized solutions that address the unique challenges faced by its clients.

Today, KBMC stands as a testament to excellence, dedication, and innovation, empowering businesses to thrive in an increasingly competitive market. With a strong foundation built on trust, quality, & expertise, KBMC is poised to continue its legacy as a leading force in Pakistan's paper and packaging industry.



# COMPLETE PAPER MACHINES

- WRITING / OFFSET PAPER
- KRAFT / LINER PAPER
- TISSUE PAPER
- UNCOATED BOARD
- WHITE COATED BOARD
- SPECIAL PAPERS

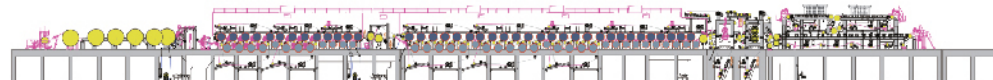

# PAPER MACHINE WET SECTION - HEADBOX

The Headbox plays a vital role in determining the quality of the final paper product. Its design and performance can significantly impact paper machine efficiency, productivity, and overall paper quality. The headbox is responsible for distributing the pulp evenly across the wire (or fiber) to create a uniform paper sheet. It ensures a stable distribution of fibers, promoting consistent paper thickness, density, and quality.

- HEADBOX TYPES
- AIR CUSHIONED HEADBOX
- HYDRAULIC HEADBOX
- OPEN/CLOSE HEADBOX
- HYDRAULIC CRESCENT FORMER
- CYLINDER FORMER
- VACUUM CYLINDER FORMER



# PAPER MACHINE WET SECTION - DEWATERING ELEMENTS

Dewatering elements in a paper machine are components that help remove water from the pulp as it passes through the machine. These elements work together to reduce the water content in the pulp to create a solid paper sheet.

Common dewatering elements in a paper machine include Forming boards, Hydrofoils, High Vacuum Boxes, Low Vacuum Boxes and UHLE tubes. Our product range includes silicone nitrate, 99% ceramic and 97% ceramic grades for covers. All boxes are made in SS 304 material.

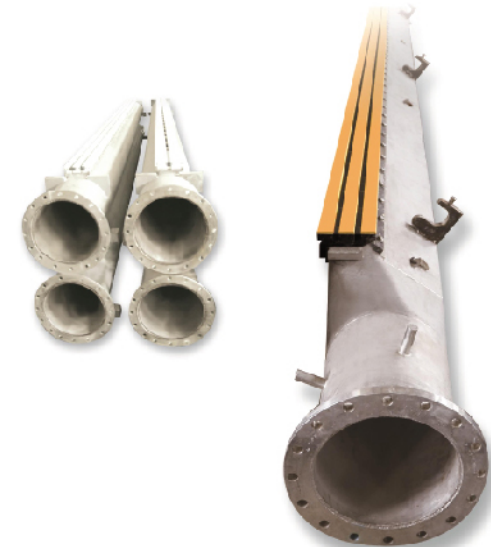
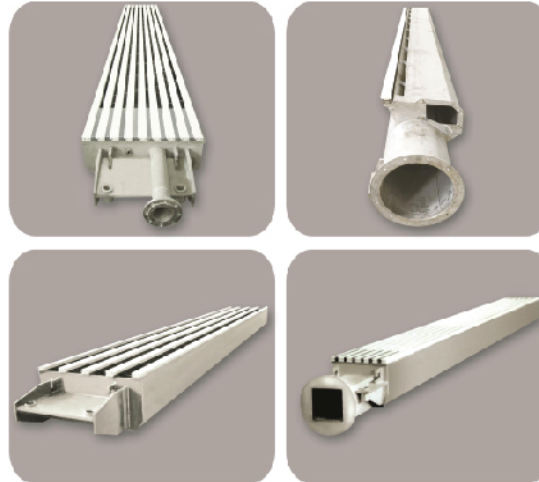

## FORMING BOARD & HYDROFOILS

- Best choice of dot
- Improve paper quality
- One time made ceramic
- Stable structure
- High strength matrix of fiber glass/carbon fiber
- Firmly fixed structure
- Easy to replace
- Long service life

## HIGH & LOW VACUUM COVERS

- Low friction coefficient
- Stable structure
- High-strength matrix of fiber glass/carbon fiber
- Firmly fixed structure
- Easy to replace
- Low adhesive rate for mixtures
- Movable bar
- Effectively protect forming wire

## UHLE TUBES

- New Material(Al<sub>2</sub>O<sub>3</sub>, ZrO<sub>2</sub>, Si<sub>3</sub>N<sub>4</sub>)
- Low friction coefficient
- Stable structure
- High-Strength matrix of fiber glass/carbon fiber
- Firmly fixed structure
- Easy to replace
- Low adhesive rate for mixtures
- Movable bar
- Effectively protect felt

# PAPER MACHINE PRESS

Press rolls are a critical component in the papermaking process. They are large, cylindrical rollers that are used to remove excess water from the paper pulp, flatten, and dry the paper sheet.

Press rolls are designed to squeeze out water from the paper pulp, remove excess moisture, and flatten the paper sheet to the desired thickness. These rolls are designed to apply high pressure to the paper pulp, typically in the range of 100-500 kN/m (kilonewtons per meter).

## TYPES OF PRESS ROLLS

- GRANITE ROLLS
- PLAIN RUBBER ROLLS
- GROOVED / BLIND DRILLED
- SUCTION PRESS ROLLS
- K-PRESS
- SHOE PRESS



# PAPER MACHINE DRYING SECTION

Dryer and MG cylinders are steam-heated cylinders, which key role in removing moisture from the paper sheet after it has been formed and pressed.

Dryer cylinders are responsible for evaporating the remaining moisture from the paper sheet, typically between 40-60% moisture content, to a final moisture level of around 5-10%. Dryers are typically located in the drying section of a paper machine, after the press section. They operate at high temperatures, typically between 100-180°C and under moderate pressure, typically around 1-5 bar.

## SPECIFICATIONS

- Material: **Cast Iron FC 30**
- Designed speed: **upto 800mpm**
- Test Pressure: **upto 12bar**



# PAPER MACHINE SIZE PRESS

Sizing press plays a crucial role in enhancing the paper's absorption properties as it applies a starch layer, known as size, to the paper sheet to improve its strength, water resistance, and printability. The sizing press helps to improve the overall quality and performance of the paper, making it more suitable for various applications, such as printing, writing, and packaging

The sizing press applies a controlled amount of water proofing chemical to the paper sheet, which penetrates the paper & helps to:

- Improve paper strength and durability
- Reduce water absorption and improve water resistance
- Enhance printability and ink retention

It is typically located in the paper machine after the dryer section, just before the reel and consists of a series of rollers, including:

- A metering roller that applies the size
- A transfer roller that transfers the size to the paper
- A pressure roller that ensures even application

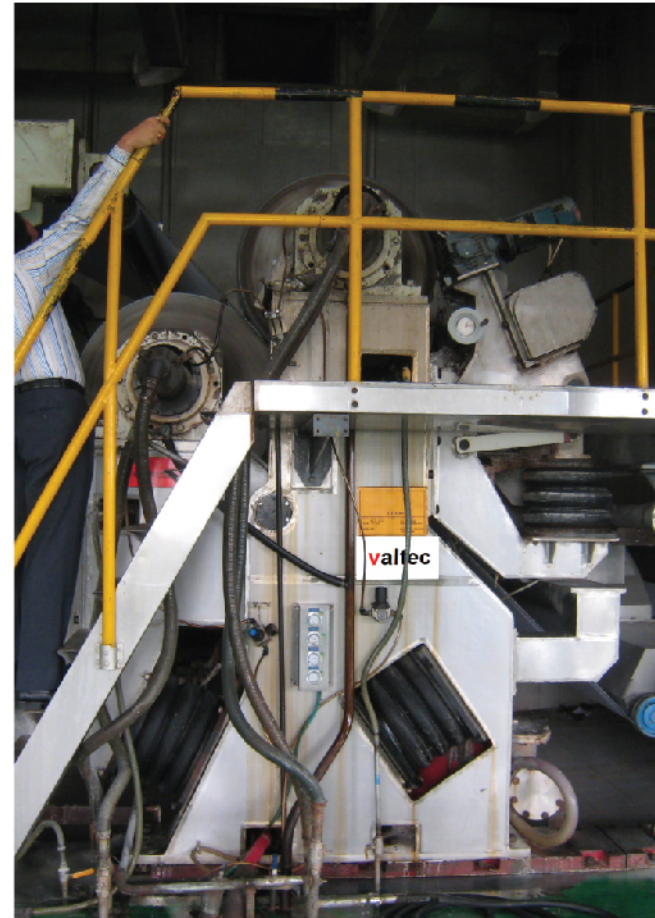

FILM SIZING PRESS ALSO AVAILABLE  
FOR HIGH SPEED PAPER MACHINES.



# PAPER MACHINE FINISHING - CALENDAR MACHINE

A calendar is a series of rollers that press and smooth out the paper sheet to achieve the desired thickness, density, and surface finish. The calendar is typically located after the press section and before the reel. Calendaring smooths out the paper sheet, removing any wrinkles, air pockets, or excess moisture. It normally consists of a series of rollers, typically 2-4, arranged in a stack. The paper sheet passes through the calendar, where it is subjected to high pressure and heat. This causes the fibers to bond together, resulting in a denser and smoother paper. By adjusting the calendar's pressure, temperature, and roller configuration, papermakers can achieve specific paper properties and qualities.

## ADVANTAGES

- Improves paper smoothness and gloss
- Enhances printability and writability
- Increases paper density and strength
- Reduces paper thickness variations

## TYPES OF CALENDAR

- **Soft calendar:** Uses soft, deformable rollers for gentle smoothing
- **Hard calendar:** Uses hard, non-deformable rollers for intense smoothing
- **Multi-nip calendar:** Uses multiple rollers with precise gap control for high-precision smoothing

### TECHNICAL DATA

• Alloy layer	10-30mm
• Nickel Alloy	3.8-4.5%
• Surface Strength	HS68-75
• Compressive Strength	>500 N/mm <sup>2</sup>
• Yield Strength	>320 N/mm <sup>2</sup>
• Elongation	1.7X10 <sup>-2</sup> N/mm
• Modulus of Elasticity	> 0.22



# PAPER MAKING FELTS

Paper making felts are specialized fabrics used in the paper making process to support and dewater the paper sheet during its formation. They are typically made of synthetic or natural fibers, such as polyester, polyamide, or cotton, & are designed to withstand the high temperatures, pressures, and chemical conditions encountered in paper mills.

## KBMC FELTS ADVANTAGES

- **Support:** They provide a smooth, even surface for the paper sheet to form on.
- **Dewatering:** They help remove excess water from the paper sheet.
- **Pressing:** They assist in pressing the paper sheet to remove excess water and flatten it.
- **Cleaning:** They can be used to clean the paper machine and remove impurities

## PRODUCT DISPLAY

### Packing Paper Felts for high speed

#### Application

Apply to high speed PM with suction press, blind with drilled press (blind drilled+ grooving), or shoe press

PM Speed : 700~1000 m/min  
Paper Grade : 50~450 g/m<sup>2</sup> packing paper

#### Technical Parameters

Weight : 1400~2200 g/m<sup>2</sup>  
Thickness : 3.5~4.2 mm  
Air Permeability : 50~90 cfm (can be adjusted for customers requirement)  
Mesh : Endless weaving technology, DCS stable structure  
Batt : Full imported fiber, Bico, smooth surface

#### Technical Superiority

Short break in time  
Running stability  
Compacted resistance

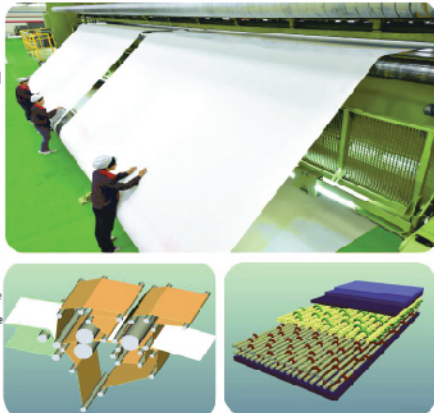

### Packing Paper Felts for Ultra-Former/ Multi Vat PM

#### Application

Apply to All types of Ultra-Former/ Multi Vat PM

PM Speed : 100~600 m/min  
Paper Grade : 300~1500 g/m<sup>2</sup>

#### Technical Parameters

Weight : 900~1300 g/m<sup>2</sup>  
Thickness : 2.4~3.2 mm  
Air Permeability : 70~120 cfm  
length : ≤150 m  
Mesh : Endless weaving technology, DCS stable structure  
Batt : Full imported fiber, Bico, smooth surface

#### Technical Superiority

High tenacity  
Dimensionally stable  
Strong adaptability

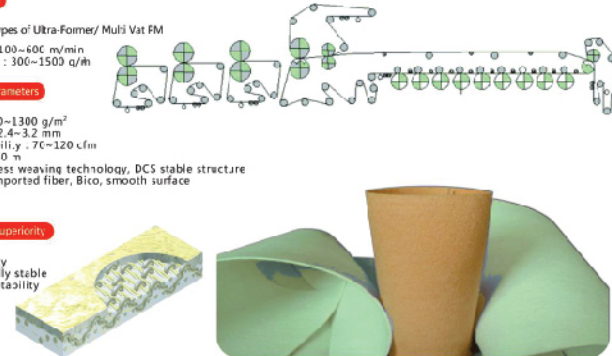

# FORMING FABRICS

Forming wires are used in Wet section to form the paper sheet during the initial papermaking process. They are typically made to withstand the high temperatures, pressures, and chemical conditions encountered in paper mills. A good fabric helps to form the paper fibers into a sheet, allowing water to drain through in order to remove excess moisture from the paper sheet.

## KBMC's FORMING FABRIC ADVANTAGES

- 1 Improved paper quality:
- 2 Increased productivity:
- 3 Enhanced dewatering:
- 4 Reduced energy consumption:
- 5 Increased wire life:
- 6 Better paper formation:
- 7 Improved paper strength:
- 8 Reduced chemical usage:
- 9 Improved machine cleanliness:
- 10 Cost savings:

## AVAILABLE DESIGNS

- Single Layer
- 1.5 layer
- 2.5 layer
- SSB Triple Layer



# PULPING SYSTEMS - BATCH OR CONTINUOUS TYPES

Paper Mills can choose to either install Batch Pulping or Continuous Pulping Process depending on their production capacity.

The continuous pulping process is a method of producing pulp for papermaking that involves a continuous flow of raw materials through a series of processing steps. This process is in contrast to the traditional batch pulping process, where raw materials are processed in discrete batches.

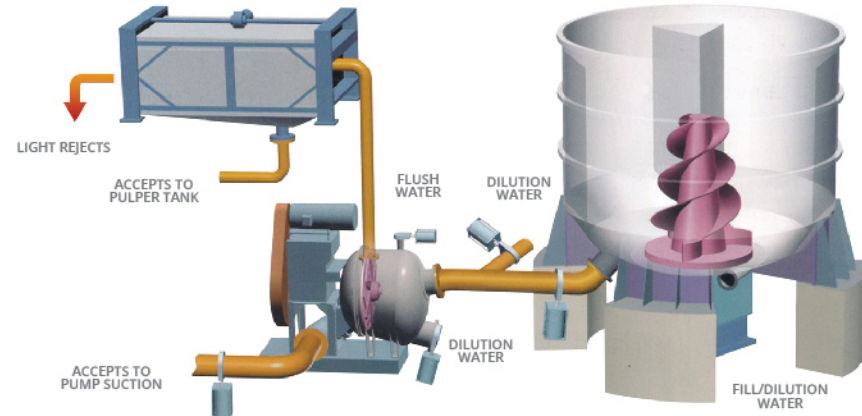

## THE CONTINUOUS PULPING PROCESS HAS SEVERAL ADVANTAGES OVER THE TRADITIONAL BATCH PULPING PROCESS, INCLUDING:

- 1 Increased efficiency: The continuous process allows for a higher production rate and reduced downtime.
- 2 Improved consistency: The continuous process produces a more consistent pulp quality.
- 3 Reduced energy consumption: The continuous process uses less energy than the batch process.
- 4 Reduced chemical usage: The continuous process uses fewer chemicals than the batch process.
- 5 Improved safety: The continuous process is safer as it eliminates the need for manual handling of hot and hazardous materials.

# STOCK PREPARATION MACHINES - PULPER

Pulper responsible for processing and breaking down raw materials, such as wood chips, recycled paper, or plant fibers, into a pulp slurry. This pulp is then used to form the paper sheet. It is typically located at the beginning of the Pulping process and helps in creating uniform consistency and texture of pulp

## D-PULPER LOW ENERGY WITH HIGH EFFICIENCY

D-type pulpers have a high pulping efficiency, which means they can process a large amount of pulp in a short amount of time. They consume less energy compared to other types of pulpers, making them a cost-effective option. They have a gentle pulping action, which helps to preserve the fiber length and strength, resulting in a higher quality paper. D-type pulpers can handle a wide range of pulp consistencies, making them versatile and adaptable to different paper making processes.

**Specification:** 15m<sup>3</sup> ~ 120m<sup>3</sup> | **Processing capacity:** 80~ 1200TPD



Model	Capacity(μ24h)	Effective Volume (m <sup>3</sup> )	Stock Consistency (%)	Motor Power (KW)
ZDS15	100~150	15	3~5	165
ZDS20	150~200	20	3~5	185
ZDS25	200~250	25	3~5	220
ZDS30	250~300	30	3~5	280
ZDS35	300~350	35	3~5	315
ZDS40	350~400	40	3~5	355
ZDS45	400~450	45	3~5	400
ZDS50	450~500	50	3~5	450
ZDS60	500~550	60	3~5	560
ZDS70	600~700	70	3~5	630
ZDS80	700~800	80	3~5	710
ZDS90	800~900	90	3~5	900
ZDS100	900~1100	100	3~5	1120

# STOCK PREPARATION MACHINES - RAGGER & GRAPPLE

## RAGGER

Ragger is used to remove light impurities in Pulper, such as iron wire, plastic, cotton yarn etc, are constantly wound and twisted into a strand rope, which is pulled out of the pulper and eliminated under the control of the rope twisting

## GRAPPLE

The grapple works by using its claws or fingers to grab and pull out the impurities from the pulp. The grapple may be used in conjunction with other cleaning devices, such as screens and filters, to remove smaller impurities.

**Specification:** 0.05 m<sup>3</sup> ~ 120m<sup>3</sup>



Model	I	II
Rolling Speed (m/h)	30	30
Motor Power (KW)	1.1	5.5
Loading/Pressurization Mode	Pneumatic	

# STOCK PREPARATION - SECONDARY PULPER & DRUM SCREEN

A Poire (or Secondary Pulper) is used in continuous pulping process as It mixes and pulps fibre, breaks down lignin and other impurities and creates a consistent and uniform pulp. It helps to remove impurities and contaminants and improves pulp strength and quality



Model	ZSF1	ZSF2	ZSF3
Nominal Volume	1.2	3	5
Treatment Density (%)	3-5	3-5	3-5
Processing Power	35-45	60-80	100-130
Motor Power (KW)	45-55	75	160
Out Size (mm)	3350X2350X1565	3760X1750X2700	4650X2000X3200

A Drum Screen is a type of screening device used to remove impurities and contaminants from the pulp. It is a rotating drum with a perforated or slotted surface, typically made of metal that allows the pulp to pass through while keeping larger impurities and contaminants inside the drum.. It helps to reduce downtime by removing impurities and contaminants that can cause paper machine breakdowns.



Model	YTS1000	YTS1500	YTS2500
Throughput (m3/min)	2-5	3-6	4-8
Drum Size (mm)	Φ1000	Φ1500	Φ2500
Screen Slot Diameter (mm)		Φ8-Φ 14	
Motor Power (KW)	5.5	5.5	18.5

# STOCK PREPARATION - COARSE SCREENING SYSTEM

The coarse screening system is the most important impurity in the whole pulping system. The final pulp clean degree, and fiber loss rate, will be affected by the advantages and disadvantages of the coarse screening system to the greatest extent. When the volume of light impurities is relatively large, it is easier to discharge out of the system, reduce the loss of fiber, and reduce the impurity fragmentation, which is of great help to the subsequent processes. Coarse screening is usually done early in the pulping process, often immediately after the Pulper, to remove large impurities that could cause problems in subsequent processing stages or damage equipment.

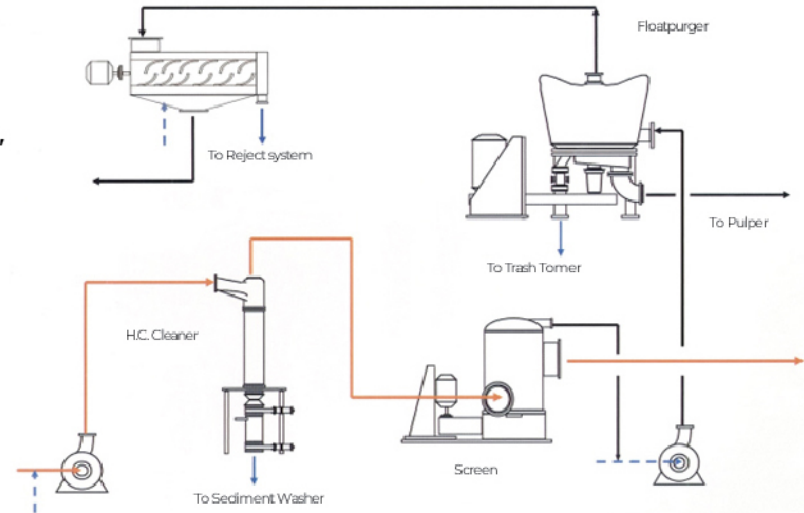

Model	SCS0.8	SCS1.2	SCS1.8	SCS2.3	SCS3.0	SCS3.6	SCS4.0	SCS5.0
Power (KW)	37	45	55-75	75-90	110	132	160	185
Sieve hole (mm)	1.8-2.6							
Sieve Seam (mm)	0.5-0.7							
Inlet Consistency (%)	2.5-3.5							



# STOCK PREPARATION - COARSE SCREENING SYSTEM

High Density Cleaner (HDC) is a type of cleaning device used to remove impurities and contaminants from the pulp. It works on the principle of centrifugal separation, where the pulp is fed into a cylindrical vessel and subjected to a high-speed rotation, creating a centrifugal force that separates the impurities from the pulp. The impurities are then removed from the pulp through a series of nozzles or outlets. The HDC is typically used to remove impurities such as Dirt, Sand, Metal, Plastic and Other high-density contaminants.



Float Purger is a device used to remove impurities and contaminants that float on the surface of the pulp. It is a type of cleaning device that uses a combination of gravity and centrifugal force to separate and remove impurities such as Plastic, Wax, Resin, Oil and other hydrophobic (water-repelling) substances



Model	TGC1	TGC2	TGC3	TGC4	TGC5	TGC6	TGC7	TGC8	TGC9	TGC12
Inlet Consistency (%)	3%-5%									
Inlet Pressure (MPa)	0.2-0.5									
Flow Rate (m3/min)	0.9-1.5	1.2-1.8	1.7-3.2	2.5-4.5	4.5-5.0	5.0-6.0	6.0-7.5	7.5-8.5	8.5-10	10-12

Model	ZSQ0.8	ZSQ1.2	ZSQ1.5	ZSQ2.0
Nominal Volume (m3)	0.8	1.2	1.5	2.0
Treating Consistency (%)	0.5-2			
Capacity (t/d)	65-80	80-100	100-120	120-135
Power Of Motor	55	75	90	110

# STOCK PREPARATION - REJECT SORTER & THICKNER

A thickener is a device used to increase the consistency and viscosity of the pulp before it is formed into paper. The pulp enters the thickener and is retained for a period, allowing excess water to drain through the screens or plates. The pulp consistency increases as the water content decreases.

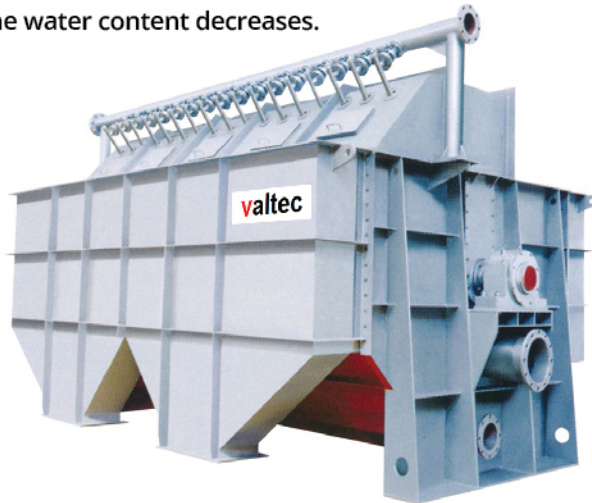

Model	ZNP2510	ZNP2512	ZNP2514	ZNP2516	ZNP3510	ZNP3512	ZNP3514	ZNP3516	ZNP3518
Diameter of Disc (mm)	2500	2500	2500	2500	3500	3500	3500	3500	3500
Number Of Disc (n)	10	12	14	16	10	12	14	16	18
Nominal Area (m2)	75	90	105	120	150	180	210	240	270
Inlet Consistency (%)	0.8-1.2								
Outlet Consistency (%)	3.5-4.5								
Capacity t(m2·d)	ONP				0.9-1.2				
	AOCC				1.5-2.4				
Motor Power (KW)	11		15		18.5		22		30

Float Purger is a device used to remove impurities and contaminants that float on the surface of the pulp. It is a type of cleaning device that uses a combination of gravity and centrifugal force to separate and remove impurities such as Plastic, Wax, Resin, Oil and other hydrophobic (water-repelling) substances



Model	ZSZ1	ZSZ2	ZSZ3
Standard (mm)	Φ280	Φ380	Φ410
Inlet Consistency (%)	1-3.5	1-3.5	1-3.5
Reject Consistency (%)	15-20	15-20	15-20
Capacity (T/D)	10-20	20-35	45-60
Power Of Motor (KW)	37	45-55	55-75

# FINE SCREENING - (OUTFLOW & INFLOW PRESSURE SCREENS)

In the pulping process, fine screening refers to the removal of small impurities and contaminants from the pulp using a screen or a series of screens with small openings or slots. The goal of fine screening is to remove small dirt particles, fiber bundles, shives, small plastic particles and other small impurities



**OUTFLOW FINE PRESSURE SCREEN**

Model	STN0.6	STN0.9	STN1.2	STN 1.5	STN2.0	STN2.5	STN3.5	STN4.5	STN6.0
Inlet Consistency (%)	0.5-1.2								
Inlet Pressure (MPa)	0.1-0.3								
Motor Power (KW)	15-22	18.5-30	22-37	30-45	37-55	37-75	45-110	55-132	75-160
Capacity (t/24h)	20-30	25-60	30-80	40-120	80-210	100-230	140-280	180-350	230-500

Fine screening is typically done after coarse screening and cleaning, and is used to further refine the pulp and improve its quality.

Fine screens are designed to remove smaller impurities than coarse screens, and are typically used to produce high-quality pulp for printing papers, writing papers, and other specialty papers.



**INFLOW FINE PRESSURE SCREEN**

Model	JS0.8	JS1.2	JS1.5	JS2.0	JS2.5	JS3.0	JS4.0	JS4.5
Sieve Size (mm)	Φ 1.2 - Φ 3.0							
Seam Size (mm)	0.15 - 0.75							
Capacity (T/D)	35-120	70-180	90-220	110-280	140-320	180-350	220-450	350-500
Slurry Inlet Concentration (%)	0.8 - 3							
Pulling Pressure (Mpa)	0.1 - 0.4							
Motor Power (KW)	45-75	45-75	55-75	75-90	90-110	110-160	160-185	185-220
Net Weight (kg)	1670	2150	3100	3500	3800	6000	7500	10200
Overall Dimensions (mm)	1860X1000X1750	1910X1050X1910	1910X1050X1910	2720X1560X2460	2995X1470X2550	3120X1660X2730	3590X2000X2928	3590X2000X2928

# DOUBLE DISK REFINER

---

A double disk refiner helps to refine and develop the pulp's properties, such as fiber length, strength, and flexibility. It consists of rotating disks with serrated surfaces that crush and fiberize the pulp, producing a more uniform and refined consistency. The pulp enters the refiner and is subjected to intense mechanical energy as it passes between the rotating disks. This process refines the fibers, develops burst strength in paper and enhances pulp uniformity



# DISC HEAT DISPERSION

The system is suitable for all kinds of pulp treatment with waste paper as the basic raw material. It can effectively disperse the impurities such as adhesive, grease, paraffin, plastic and ink particles in waste paper pulp, so as to improve the quality of paper and improve the performance of Disc heat dispersing system mainly includes: shredding machine, heater, feeding screw conveyor and disc heat dispersing machine.

The concentration of the slurry is increased to about 30% by the concentrator, which is sent to the heat dispersion system. The plug screw conveyor is used to prevent steam overflow, the slurry is scattered by the shredding machine, and the slurry is heated by the heater, and then dispersed by the disc heat dispersion.

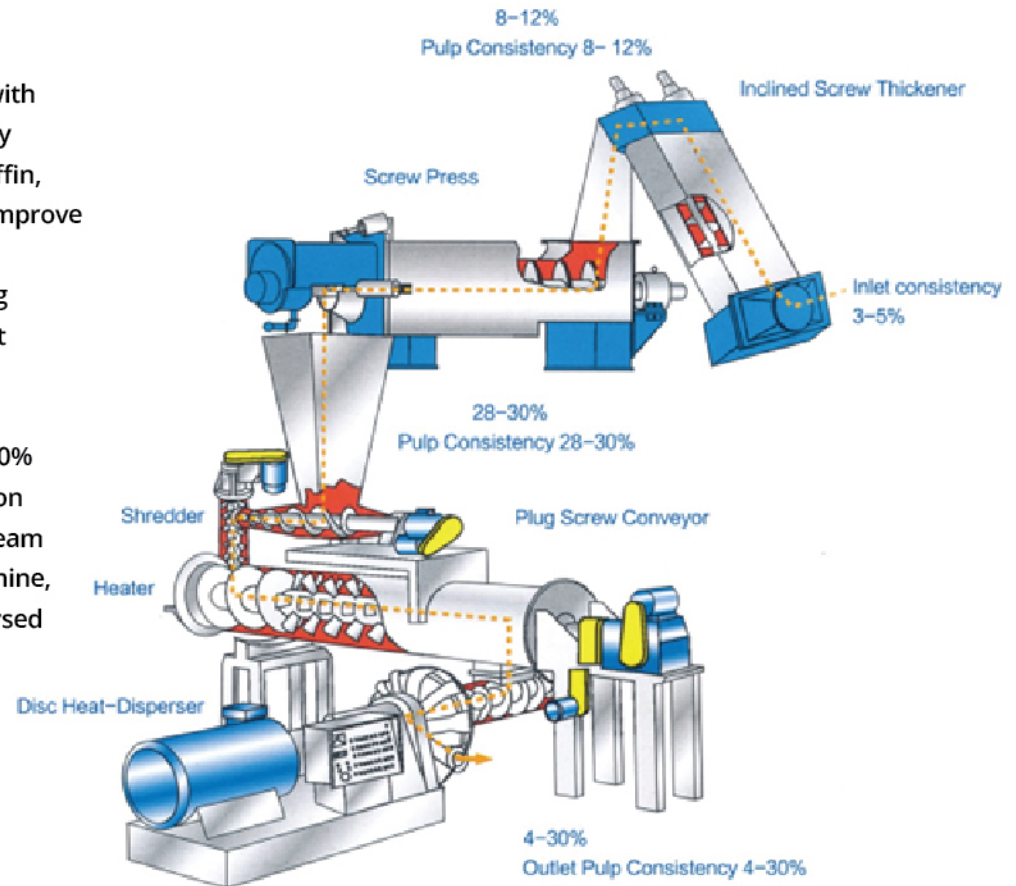

# PAPER FINISHING MACHINES - HI SPEED ROLL TO SHEET CUTTER

Our Servo Precision High Speed Sheet Cutters are high-precision and efficient cutting equipment helps to achieve increased productivity with improved accuracy. Equipped with top quality Servo Control System, the machine can handle large paper reels and produce individual sheets in a single operation. It has slitting function which helps to cut horizontally as well as vertically. Its accurate sheet counting feature helps to control losses which occurs due to manual counting. The touchscreen makes the operation easy and reduce labour costs. The machines are designed with improved safety measures such as automatic shut-off to protect operators from injury

## SM SERIES - DOUBLE KNIFE

Available in 1400 / 1700 / 1900 sizes

## OPERATING SPEED

Available in 1400 / 1700 / 1900 sizes

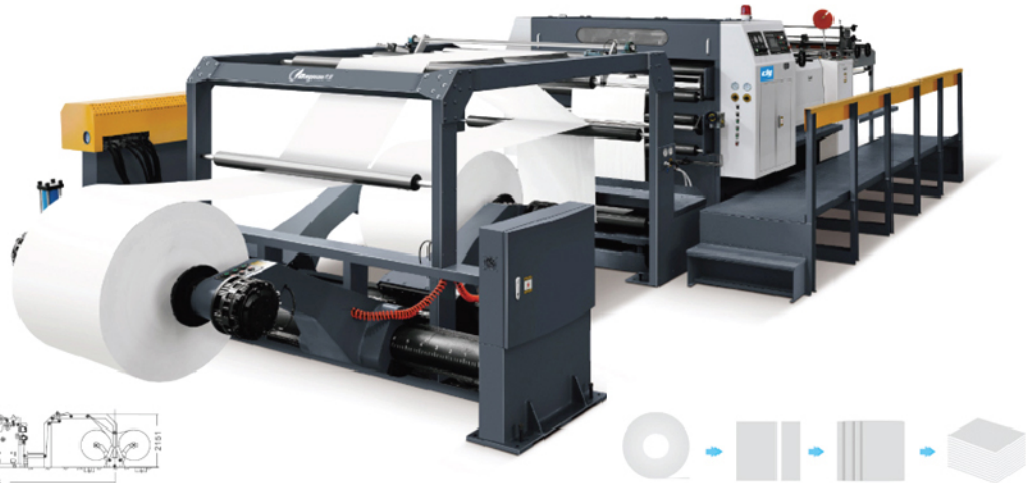
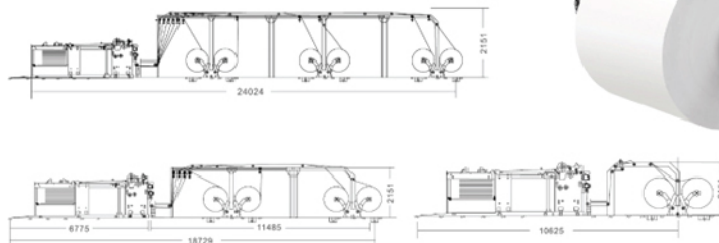

# PAPER FINISHING MACHINES - HI SPEED ROLL TO SHEET CUTTER

## CM SERIES – SINGLE KNIFE

Available in 1400 / 1700 / 1900 sizes

## OPERATING SPEED

Upto 400MPM

Main Technical Parameter	
Model	CM-1100A/ 1500A/ 1700A/ 1900A
Model Of Cutting Power	The upper knife cuts back and the lower knife is fixed
Thickness Of Cutting Paper	The up Knife Cut reciprocally and the down Knife is Fixed
Max. Scroll Diameter	60-550g
Max. Paper Cutting Width	1800mm
Cutting Length Range	1100mm/1500mm/1700mm/1900mm
Cutting Precision	450-1650mm
	Cut off length ≤1000mm: +/-0.5mm Cut off length >1000mm: +/-0.1%
	Cutting lengths ≤1000mm : +/-0.5mm
Max. Cutting Speed	Cutting Length >1000mm : +/-0.1%
Max. Cutting Meter Speed	400cuts/min
Max. Paper Piling Height	300m/min
The Request For Air	1500mm
Compressor	0.8Mpa
Power Consumption	380V / 220Vx50Hz
Gross Weight	9000Kgs/ 11000Kgs/ 13000Kgs/ 15000Kgs
Full-load Power	22 / 26 / 30 / 35Kw



# TISSUE CONVERTING MACHINES

## FACIAL TISSUE CUTTING MACHINE

The folding of product is "V" type folding and cutting and you can draw it one by one. This kind of towel paper is used widely in hotel, office and kitchen etc, that is convenient and sanitation. We adopt original creation full absorption technology, the adaptability of raw material is so strong. The folding, cutting, counting, embossing, several processes are going together.



Complete lines available for:

- Toilet Roll
- Kitchen Towel
- Kitchen Napkin
- Pillow or Box Packing



# VACUUM SYSTEMS

## TURBO VACUUM / TURBINES

Turbo vacuum pumps, also known as turbomolecular pumps (TMPs), are a type of high-performance vacuum pump commonly used in various scientific, industrial, and research applications. They operate based on the principle of molecular drag, utilizing the kinetic energy of gas molecules to create a pumping action.

### Types of Turbo Vacuum Pumps:

Turbo vacuum pumps, also known as turbomolecular pumps (TMPs), are a type of high-performance vacuum pump commonly used in various scientific, industrial, and research applications. They operate based on the principle of molecular drag, utilizing the kinetic energy of gas molecules to create a pumping action.

- Single-stage
- Two-stage

Turbo blowers are designed to operate efficiently across a wide range of vacuum levels and air flows. It allows paper mills to optimize vacuum levels whilst taking advantage of the higher efficiency a blower has over a traditional liquid ring pump device



**ROOTS TYPE  
VACUUM PUMP**



**LIQUID RING  
VACUUM PUMP**

Different models available  
According to vacuum needs And capacities

# PAPER TESTING INSTRUMENTS



**CRUSH TESTER**



**BENDING TESTER**



**COBB TESTER**



**BURST TESTER**



**DRY OVEN**

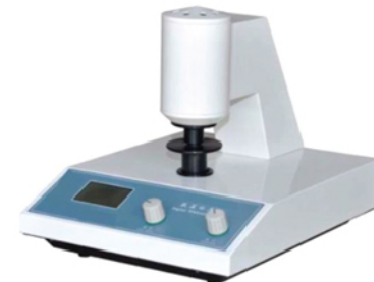

**WHITENESS TESTER**

# PAPER TESTING INSTRUMENTS



**CRUSH TESTER**



**PLYBOND TESTER**



**TEAR TESTER**



**SMOOTHNESS TESTER**



**BRIGHTNESS &  
OPACITY TESTER**



**MOISTURE METER  
FOR WASTE**

# SPARE PARTS - PULP & PAPER MACHINES



**SCREEN BASKETS**



**CERAMIC NOZZLES**

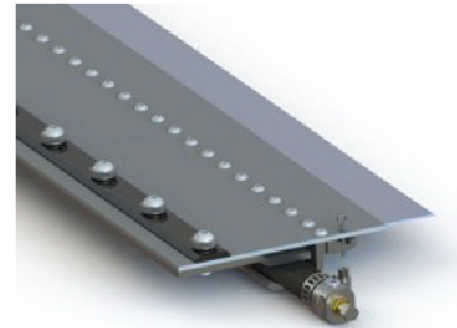

**DOCTOR BLADES**



**SCREEN ROTORS**



**SHOWER NOZZLES**

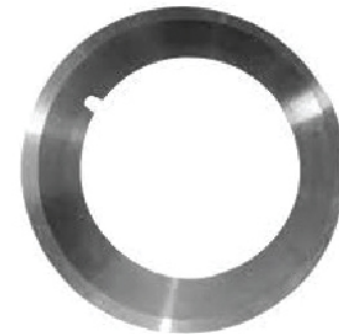

**REWINDER KNIVES**

# SPARE PARTS



**PULP VALVES**



**MECHANICAL SEALS**



**STEAM ROTARIES**



**BELLOWS**



**CARBON SEALS**



**STEAM TRAPS**

# QUALITY CONTROL SYSTEM - (QCS)

---

QCS (Quality Control System) is a set of sensors, scanners, and software that monitor and control various parameters of the paper production process to ensure consistent quality.

We supplied Top Quality systems to test:

1. Basis weight (thickness)
2. Moisture content
3. Caliper (thickness)
4. Density
5. Ash content
6. Color
7. Formation (paper structure)
8. Web tension

---

The above QCS data can be linked to DCS (Decision Control System) which provides following benefits:

1. Adjust machine settings for optimal performance
2. Detect anomalies and defects
3. Provide real-time quality monitoring
4. Enable predictive maintenance
5. Optimize paper quality and reduce waste



# OUR CLIENTS

## Overseas Clients

(using our machinery & equipment)

1. Al Haram Paper - Afghanistan
2. Isfahan Paper - Iran
3. Keihan Kaghaz - Iran
4. Papertech - Bangladesh
5. Persia Golistan Paper Mill - Iran
6. Sepehr Kaghaz Spadana Co - Iran
7. Sherkat Khaqaz Moqawa - Iran
8. Shirkat-e-Simeen Kaghaz - Iran
9. Yazd Paper - Iran

## Domestic Clients

(using our machinery & equipment)

1. Aaj Paper
2. Ahmed Straw Paper Mill
3. Al Asar Paper
4. Al Mezaan Paper
5. Al Rehman Board, Faisalabad
6. Al Rehman Paper, Sheikhpura
7. Alkaram Paper Mills
8. Arsam Paper & Board Mills (former Sanpak)
9. ASL Paper Mills
10. Awais Usama Paper Mill
11. AA Paper Mills
12. Corrubox Paper (former Olympia)

13. Crafters Paper
14. Country Paper Mills
15. Darul Ahsaan (former Tayyab) Paper Mills
16. Decent Paper Mills
17. DIC (Packages Ltd)
18. Faisalabad Paper
19. Famous Paper
20. Fazal Paper & Board Mills
21. Gold Paper & Board Mills
22. Hira Paper
23. Horizon Paper & Board Mills
24. HH Paper Mills
25. Hashmi Paper Mills
26. Indus Coating
27. Irshad Naeem Paper
28. Ittefaq Paper Mills
29. Jahangir Paper
30. Jubilee Enterprises
31. Karachi Paper & Board Mill
32. Kertas Paper & Board Mills
33. Kundi Paper Mills
34. Kamonkee Paper
35. Lasani Paper Mills
36. Model Paper Mills
37. Mamel Paper
38. MM Paper & Board Mill

39. Mirpurkhas Paper Mills (MSM)
40. Moiz Nawab Paper Mill
41. Mughal Board, Faisalabad
42. Multan Paper Mill
43. Malik Board Mills
44. Naseer Paper Mills
45. Noshahi Paper Mills
46. Pakistan State Oil (PSO)
47. Platinum Paper & Board Mills
48. Pioneer Board Mills
49. Rose Paper Mill
50. Sarhad Board Mills
51. Sayid Paper Mills
52. Shan Paper Mill
53. Shokat Paper Mills
54. Tapal Tea (Pvt) Ltd
55. Taj International
56. Tughlaq Paper Mills
57. Union Paper Mill
58. Universal Paper & Board Mill
59. Xcellent Paper
60. ZT Paper Mills

"Over 100+ other clients using our fabrics regularly every month"

**CRISTINI**  
RELIABLE INNOVATION™

**valtec**

**Dayuan**

 **盛兴烘缸**  
SHENGXING

**SICER**®



**Karachi:**  
.....

**Tel:** +92 21 3454 7126

**Fax:** +92 21 3454 7127

**Email:** [inquiry.kbmc@gmail.com](mailto:inquiry.kbmc@gmail.com)

**Address:** Suite 204 & 406, Business Centre,  
PECHS Block 6, Shahrah-e-Faisal, Karachi.

**Lahore:**  
.....

**Tel:** +92 42 3576 0841

**Fax:** +92 42 3576 0842

**Email:** [inquiry.kbmc@gmail.com](mailto:inquiry.kbmc@gmail.com)

**Address:** Al Jannat Road Chowk,  
Nainsukh Stop, Saglan Bypass, Lahore.